



MODEL 4/15

**SUPERSLIM FREE FLOAT
KEYMOD RAIL SYSTEM**
COMPATIBLE

Item No.:

MTU004SSK/MTU005SSK/MTU006SSK/MTU019SSK/MTU037SSK
& All Color Variants

- Proudly Designed and Manufactured in USA
- Keymod Compatible, Super Slim Free-floating Handguard with Proprietary Barrel Nut Design
- Super Lightweight with Top Rail Flush Fitting and Continuous with Flat Top AR15 Upper Receivers Providing Ample Real Estate for Optics and Other Accessories
- Includes 2 Keymod Compatible Picatinny Rail Sections, One 4 Slot and 8 Slot with Continuous Rail Edge Design for Accessory Mounting Right out of the Box
- Features Integral Anti-rotation Tabs for Accurate Alignment with the Upper Receiver while Preventing the Handguard From Rotating
- Ergonomic Octagonal Profile with Grooved Surface for a Solid, yet Comfortable Grip for Fast and Seamless Firearm Handling
- Scalloped Top Picatinny Rail Edges for Easy and Snag Free Accessory Mounting
- Precision Machined from 6061-T6 Aircraft Grade Aluminum with Matte Black Hard Anodizing
- Simple and User Friendly Installation with Easy to Follow Instructions Included
- Designed to Fit with Standard Gas Tube and Barrel Not Exceeding 1" in Diameter, Not Compatible with Piston System, Re-designed or Over-sized Upper Receivers



MODEL 4/15

**SUPERSLIM FREE FLOAT
KEYMOD RAIL SYSTEM**
COMPATIBLE

Item No.:

MTU004SSK/MTU005SSK/MTU006SSK/MTU019SSK/MTU037SSK
& All Color Variants

Made in USA

MODEL 4/15 RIFLE

COMPONENT REFERENCE

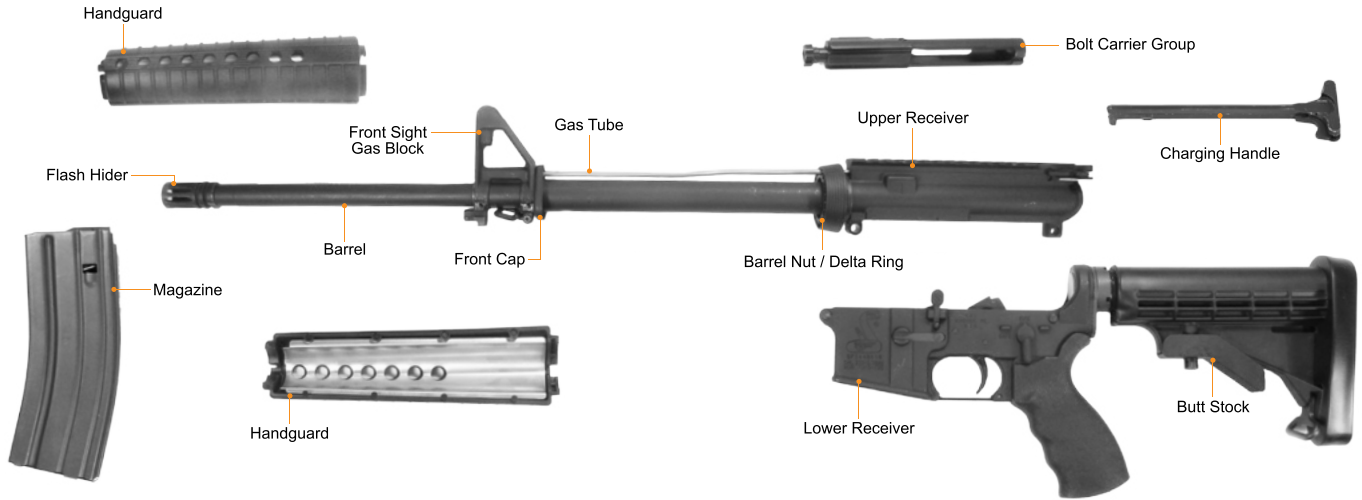

UTG INNOVATIVE FREE FLOATING DESIGN (US PAT. 8806792)

Robust Integral, Lightweight
Super Slim One-piece Handguard

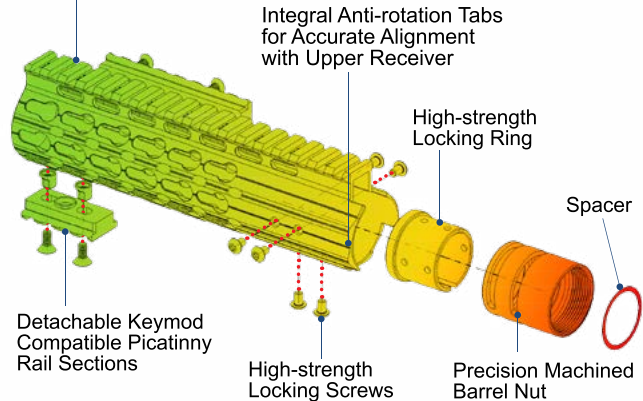

AFTER INSTALLATION

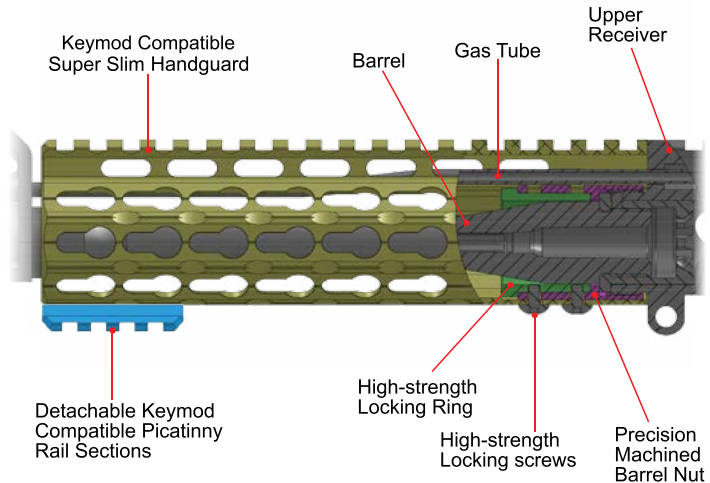

MODEL 4/15 CARBINE-LENGTH APPLICATION

- 42 Keymod Compatible Slots with 18 Slot Top Picatinny Rail, Complete with One 8-slot and One 4-slot Keymod Compatible Detachable Picatinny Rail Sections with Continuous Rail Edge Design
- Accommodates Low Profile Gas Block

**KEYMOD
COMPATIBLE**
**7" FREE FLOAT
SUPER SLIM
HANDGUARD**



MODEL 4/15 MID-LENGTH APPLICATION

- 63 Keymod Compatible Slots with 23 Slot Top Picatinny Rail, Complete with One 8-slot and One 4-slot Keymod Compatible Detachable Picatinny Rail Sections with Continuous Rail Edge Design
- Accommodates Low Profile Gas Block

**KEYMOD
COMPATIBLE**
**9" FREE FLOAT
SUPER SLIM
HANDGUARD**



MODEL 4/15 RIFLE-LENGTH APPLICATION

- 91 Keymod Compatible Slots with 31 Slot Top Picatinny Rail, Complete with One 8-slot and One 4-slot Keymod Compatible Detachable Picatinny Rail Sections with Continuous Rail Edge Design
- Accommodates Low Profile Gas Block

**KEYMOD
COMPATIBLE**
**13" FREE FLOAT
SUPER SLIM
HANDGUARD**



MTU006SSK

MODEL 4/15 EXTENDED RIFLE-LENGTH APPLICATION

- 112 Keymod Compatible Slots with 37 Slot Top Picatinny Rail, Complete with One 8-slot and One 4-slot Keymod Compatible Detachable Picatinny Rail Sections with Continuous Rail Edge Design
- Accommodates Low Profile Gas Block

MTU019SSK

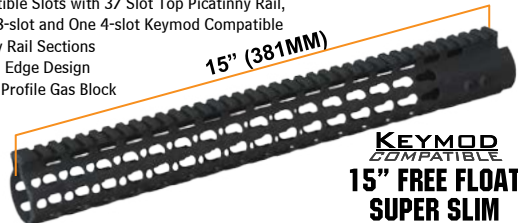

**KEYMOD
COMPATIBLE**
**15" FREE FLOAT
SUPER SLIM
HANDGUARD**

- 126 Keymod Compatible Slots with 42Slot Top Picatinny Rail, Complete with One 8-slot and One 4-slot Keymod Compatible Detachable Picatinny Rail Sections with Continuous Rail Edge Design
- Fits on 18" and 20" Rifle-length AR-15 with Standard Gas Tube
- Accommodates Low Profile Gas Block

MTU037SSK



**KEYMOD
COMPATIBLE**
**17" FREE FLOAT
SUPER SLIM
HANDGUARD**

MODEL 4/15 SUPER SLIM FREE FLOAT RAIL SYSTEM INSTALLATION GUIDE



1. Super Slim Keymod Compatible Handguard
2. Barrel Nut
3. Locking Ring
4. Barrel Nut Wrench
5. 3mm Allen Wrench
6. 3/32" Allen Wrench
7. Spacer - 4Pcs
8. 4-Slot Picatinny Rail Section (.38" Saddle Height)
9. 8-Slot Picatinny Rail Section (.38" Saddle Height)
10. Barrel Nut Locking Screw - 7Pcs



Set up a comfortable working environment. Lay out the rifle, Handguard and all the included parts & tools. For proper installation of this product, you also need to prepare the following **necessary tools**: AR-15 combo wrench, AR-15 handguard removal tool, a hammer, a punch, AR-15 upper receiver vise block, and a vise.

Caution: Make sure firearm is not loaded. Remove magazine and examine chamber. Use safe handling procedures at all times.



Remove the original plastic handguard using the handguard removal tool.



Remove the lower receiver and bolt carrier group and charging handle (3.1).



Note: Barrel Direction: ← Barrel (Pointing Left) or Barrel → (Pointing Right)



Remove the flash hider by turning it counterclockwise with an AR-15 combo wrench.



Securely place the barrel on a well padded flat surface. Using a hammer and punch, tap out the two pins at the bottom of the front sight/gas block. Remove the front sight/gas block, the gas tube, and front handguard cap (5.1).



Clamp the upper receiver on a vise with an AR-15 upper receiver vise block. Loosen the barrel nut by turning it counterclockwise with an AR-15 barrel nut wrench. Remove the original barrel nut and delta ring assembly.



Remove all parts from the package. **See Page 9 for Part Descriptions.**



Carefully read the yellow warning sticker on the Barrel Nut on which correct slot to use for installation before removing the sticker. Fit the free floating Barrel Nut on the upper receiver and hand tighten. To test alignment, fit the handguard over the barrel and place over the Barrel Nut. Ensure the threaded holes on the handguard align with the slots on the Barrel Nut (9.1-2). If the alignment is correct then move to step 10.

INCORRECT
(SPACERS REQUIRED)

CORRECT

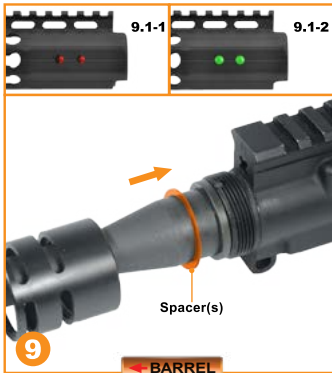

THIS STEP IS VERY RARELY NEEDED If you cannot achieve the proper alignment (9.1-1), use included Spacer(s) to achieve the proper alignment of the threaded holes on the handguard with the slots on the Barrel Nut (9.1-2).



Place the Barrel Nut Wrench in the second slot (10.1) on the Barrel Nut (closer to the receiver). **NEVER USE THE FIRST SLOT TO TIGHTEN.**

Warning: These steps need to be done gently. DO NOT tighten aggressively. Apply a smooth, steady pressure to fully secure the Barrel Nut. The teeth of the wrench must be FULLY SEATED into the 2nd slot on the Barrel Nut each time you release and apply pressure again.

Warning: Max. torque value for installing barrel nut should not exceed 60 ft-lb.



Use the Barrel Nut Wrench to securely tighten the Barrel Nut with enough tension (**35 ft-lb.**). (**We recommend using a torque wrench to achieve proper tension.**)

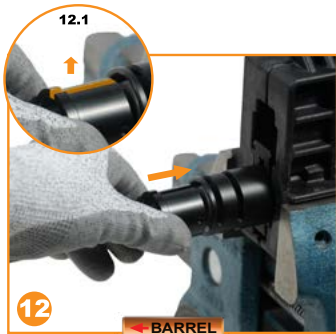

Slide the Locking Ring into the Barrel Nut, making sure the alignment slot on the Locking Ring (12.1) is vertical and facing upward.



Make sure none of the 6 threaded screw holes on the Locking Ring are blocked by the Barrel Nut. **If necessary, refer to step 9 to install a spacer or tighten the barrel nut a little further to allow access to the 6 screw holes. MAKE SURE NOT TO EXCEED 60 ft-lb OF TORQUE.**

Installation of a low profile gas block must occur before locking the Handguard to the barrel nut.



Carefully slide the handguard over the Barrel Nut/Locking Ring assembly. Make sure there is a positive connection between the top rail of the handguard and the top rail of the receiver (there should be NO gap here). If you lose the alignment of the Locking Ring, use your Allen wrench to realign the threaded holes (14.1).

If desired, apply a small amount of locking compound to the screws prior to tightening.



Once you achieve the proper alignment of the threaded holes on the Locking Ring to those on the handguard rail, use the 3mm Allen Wrench and 6 of the Locking Screws to securely lock the handguard to the Barrel Nut/Locking Ring assembly.

Apply **(25 in-lb)** torque to secure screws 6 Screws: 2-left, 2-right, 2-bottom

Attaching **KEYMOD** COMPATIBLE Picatinny Rail Sections



To install your detachable Keymod Compatible Picatinny Rail Sections or other Keymod compatible accessories, please refer to the following steps.

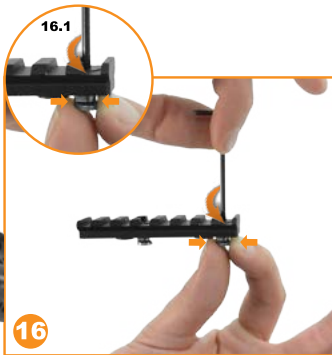

Hold the Keymod Nut in place (16.1) and loosen the screw by turning it counter-clockwise with the included 3/32" Allen Wrench. Do not fully detach the Keymod Screw from the Keymod Nut.

NOTE: The Keymod Nut and Screw can be fully disassembled if needed.



Place the rail with the Keymod Nuts onto the desired slots of the handguard, inserting the nuts through the larger opening of the Keymod Slots with the protruding feet of the nuts pointing toward the muzzle of the firearm (17.1).

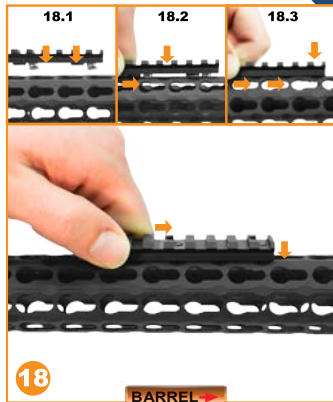

Once the Keymod Nuts are in the slots, carefully slide the Rail Section forward until it fully seats into and engages the handguard, with little to no gap between the Rail Section and the handguard. (18.1, 18.2, 18.3)

If desired, apply a small amount of locking compound to the screws prior to tightening.



Once the Rail Section is seated properly, use the included 3/32" Allen Wrench to hand-tighten the screws on top of the Picatinny Rail Section to lock it securely to the Keymod Compatible Handguard. **Do not** over-torque.



Reinstall the front sight to the gas tube. Reinstall the two pins to lock the front sight to the barrel (20.1).



Install the flash hider on the Barrel.



Re-install the bolt carrier group and charging handle back into the upper receiver. Reassemble the upper and lower receiver and proceed to function check the firearm.



Optional Step - Users may purchase additional detachable Keymod compatible picatinny rail sections for customized accessory attachment.



Optional Step - Accommodates high quality UTG accessories on the free floating slim rails, such as foregrips, bipods, flashlights, lasers, etc.

Using all appropriate safety procedures, your rifle is now ready for test firing.

DETACHABLE RAILS FOR SEPARATE SALE

0.38" Saddle Height Keymod Compatible Picatinny Rail Sections

4-Slot
MTURS04S



8-Slot
MTURS04M



PRODUCT FEATURES



Integral Anti-rotation Tabs for Accurate Alignment with the Upper Receiver



Top Rail Flush Fitting and Continuous with Flat Top AR15 Upper Receivers



Ultra Slim-line Design for Comfort and Weight Reduction

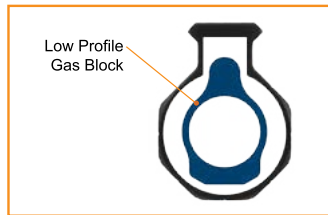

Accommodates with Low Profile Gas Block